



# PRESENTATION MANIPULATOR - M WITH SPINDLE FOR LARGE AND HEAVY SPOOLS

With the MANIBO Industrial Manipulators, a single operator can handle loads of considerable size and weight with ease and in absolute safety.

## Specifications

MANIBO presents 4 models for the series M. A wide range of manipulators with lifting capacities ranging from 150 up to 450 kg. The working radius varies, regardless of the model, from 2,7 up to 4.3 m. The manipulator can be fixed directly to the floor, motorized or mounted on a self-stable base that allows it to be used in different locations without the need for any anchoring.



## WHO WE ARE

MANIBO holds a consolidated position in the field of industrial manipulation and is now a reference partner for many leading companies not only in Italy, but throughout the world. MANIBO takes particular care in solving handling problems in the food and pharmaceutical companies, also with applications in ATEX environments. We guarantee timely responses and rapid decisions.

## WHY CHOOSE US



Our experience, professionalism and precision.



Particular attention in the testing phase, with specific tests for the use, even in ATEX environments.



Accurate design phase to adapt the manipulator to your machine and to your environment conditions.

## Safety devices

- » Block valve for arm movement, in the event of an inadvertent fall of air pressure;
- » Controlled lowering of the load in the event of a drop in air pressure;
- » Safety device to detect pressure so to avoid the release of the load when it is raised;
- » Two-hand controls for picking up and releasing the load, to avoid accidental operations;
- » Pneumatic valve to limit rapid and dangerous movements of the manipulator arm, in case of incorrect maneuvers or sudden variations of the lifted load;
- » Pneumatic valve to avoid movements of rapid and dangerous lowering of the maneuvering arm, in case of breakage of the main feeding pipe of the lifting cylinder;

**CONTACT US FOR A QUOTE**

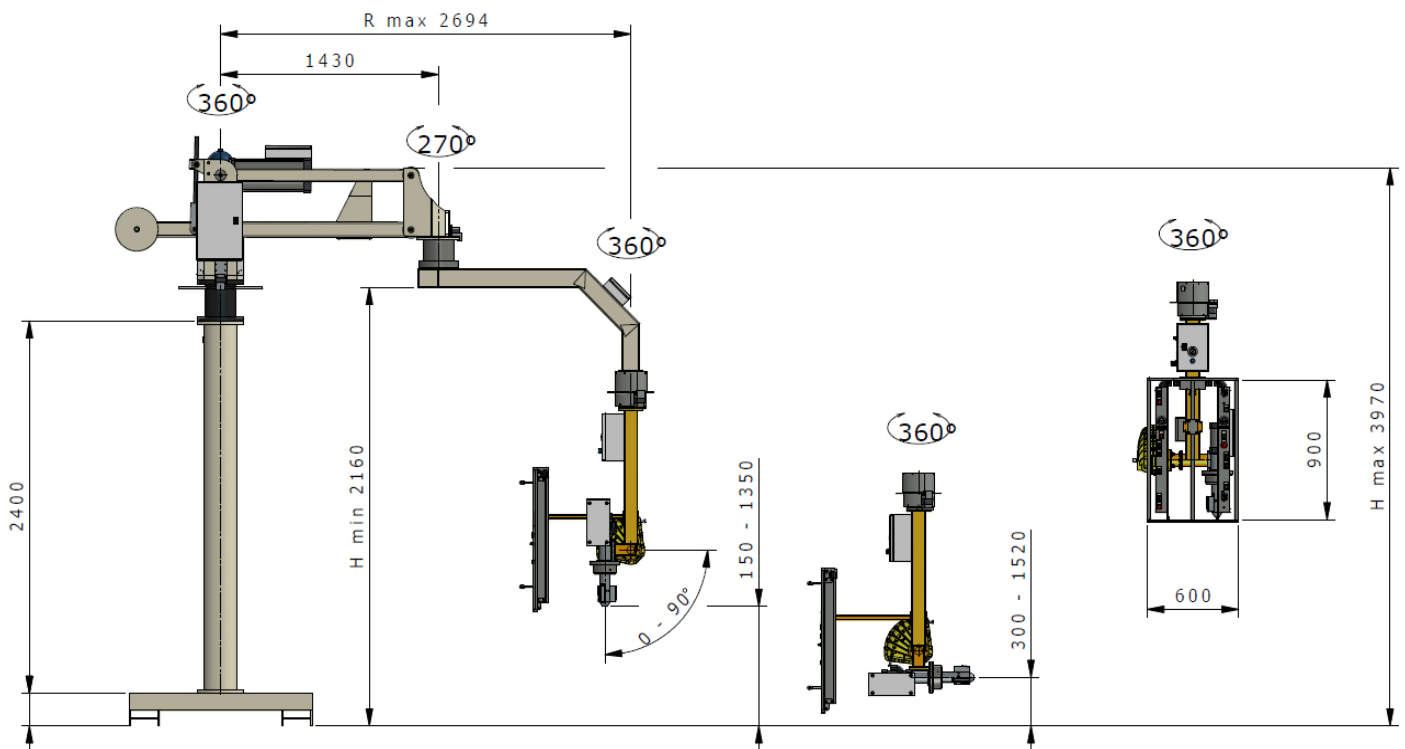

#### Technical features:

- Pneumatic power supply at 7 bar
- Maximum load 120 kg,
- Radius of action 2700 - 4300 mm (depends on the model),
- Vertical travel 1430 - 2750 mm (depends on the model),
- Executions: on a fixed base, on a self-stable base supplied by us or with a sliding motorized self-adjustable trolley along a simple rail on the floor, hanging.

#### CONTINUOUS MANUAL SPEED ADJUSTMENT - COMMAND TYPE M

Suitable for handling loads with different weights. The operator acting on the single lever, placed on the ergonomic handle, controls the lifting and the lowering of the load, with the possibility of adjusting the movements very easily.

The controls of the manipulator and the gripping equipment are located on the handle of the handling equipment. There are double controls for lifting and lowering and for gripping and releasing of the load. This type of control allows the operator to move the lifted load to any point in a balanced way. The load can be managed precisely, using only hands.

With 90° pneumatic tilting device.



Via del Lavoro 85, 40033  
Casalecchio di Reno BO



+39 (0)51 6468143



www.manibo.eu  
manibo@mani-bo.com



SCAN ME